

MATERIAL LEGEND		MATERIAL	
DESIGNATION		DESIGNATION	MATERIAL
[Hatched Pattern]			STN. STL.
[Cross-hatched Pattern]			ALUMINUM
[Diagonal Hatched Pattern]			COPPER, OFHC

OUTLINE DWG. VARIATION NO.	MODEL AND ASSY. VAR. NO.	POWER OPERATION	MINIMUM TEMP
266652D-C	266652D	50/60 Hz.	10K
266652D-N-C	266652D-N	50/60 Hz.	6.5K

PROJECT: expander\_ch204s

TITLE: OUTLINE DRAWING  
COLD HEAD ASSEMBLY  
CH-204S

DATE	BY	MFG.	QUAL.	ENGR.
12/17/10	KJJ	PZ	RGS	RBS
15 MAR 06	JPK	YB	RGS	ERS

Sumitomo  
(SHI) CRYOGENICS OF AMERICA, INC.

NO. 266652D-C  
SHEET 1 OF 2

PROPRIETARY NOTICE: THIS DOCUMENT IS THE PROPERTY OF SUMITOMO (SHI) CRYOGENICS OF AMERICA, INC., AND SHALL NOT, WITHOUT THE EXPRESS WRITTEN PERMISSION OF SCAI, BE REPRODUCED OR COPIED IN WHOLE OR IN PART BY ANY PERSON OUTSIDE OF SCAI OR, IF LOANED BY SCAI TO SUCH PERSON, SHALL NOT BE USED FOR FURNISHING INFORMATION TO ANY THIRD PARTY OR FOR ANY PURPOSE OTHER THAN THAT FOR WHICH IT IS LOANED.  
FORM NO. DD102089-A Rev. B (3/00)

2nd STAGE HEAT STATION  
MOUNTING HOLES  
M4 x 0.7-6H THD. THRU  
(6) HOLES EQ. SPACED ON  
A  $\phi$ 1.500 [38.1 mm] B.C.

1st STAGE HEAT STATION  
MOUNTING HOLES  
M4 x 0.7-6H THD. THRU  
(8) HOLES EQ. SPACED ON A  
 $\phi$ 2.625 [66.7 mm] B.C.

WARM FLANGE MOUNTING HOLES  
M6 x 1.0-6H THD. x  
.62 [15.7 mm] DP.  
(8) HOLES EQ. SPACED ON A  
 $\phi$ 4.409 [112 mm] B.C.

3.688 [93.68 mm] O.D. x  
3.448 [87.58 mm] I.D. x  
.072 [1.82 mm] DP.  
O-RING GROOVE  
O-RING SIZE 2-153

VARIABLE ORIFICE

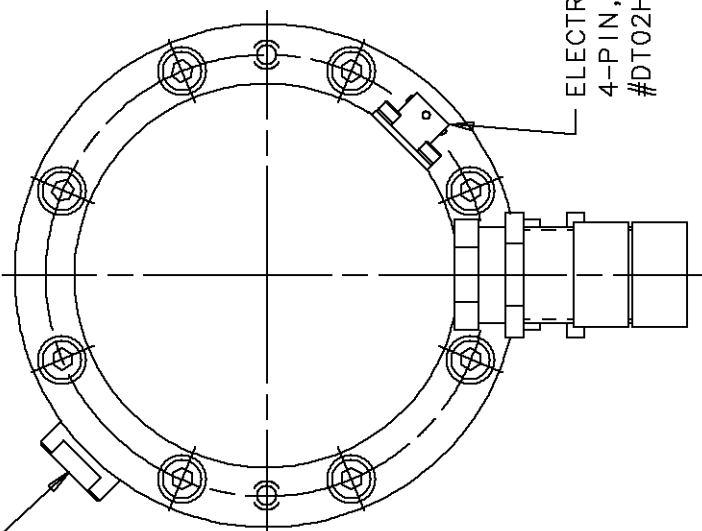

VIEW Y-Y

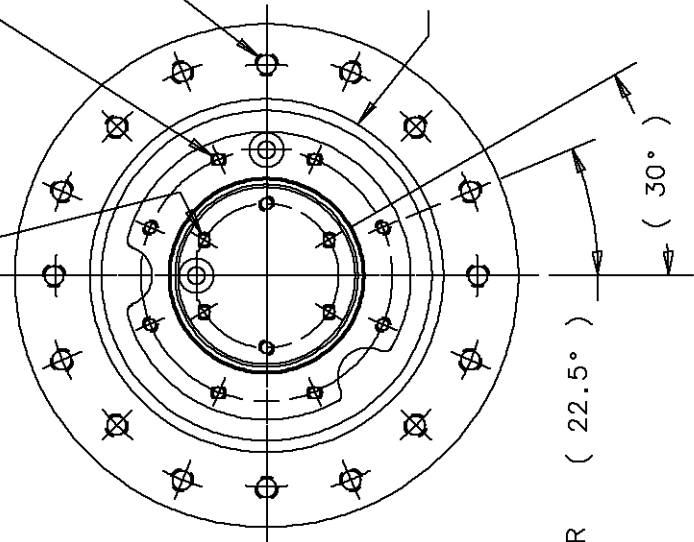

VIEW Z-Z

ELECTRICAL CONNECTOR  
4-PIN, DETORONICS  
#DT02H-8-4PN

TITLE

OUTLINE DRAWING  
COLD HEAD ASSEMBLY  
CH-204S

REV. D



NO. 266652D-C  
SHEET 2 OF 2

REV.	CRSP NO.	DATE	BY	MFG.	YB	RGS	ERS	ENGR.
		15 MAR 06	JPK					

PROPRIETARY NOTICE: THIS DOCUMENT IS THE PROPERTY OF SUMITOMO (SHI) CRYOGENICS OF AMERICA, INC., AND SHALL NOT, WITHOUT THE EXPRESS WRITTEN PERMISSION OF SCAI, BE REPRODUCED OR COPIED IN WHOLE OR IN PART BY ANY PERSON OUTSIDE OF SCAI OR, IF LOANED BY SCAI TO SUCH PERSON, SHALL NOT BE USED FOR FURNISHING INFORMATION TO ANY THIRD PARTY OR FOR ANY PURPOSE OTHER THAN THAT FOR WHICH IT IS LOANED.  
FORM NO. DD102089-A Rev. B (3/00)